



**WALRUS**  
PUMP

*WQ\_B Series*

# Instruction Manual

## Electronic Control Pump

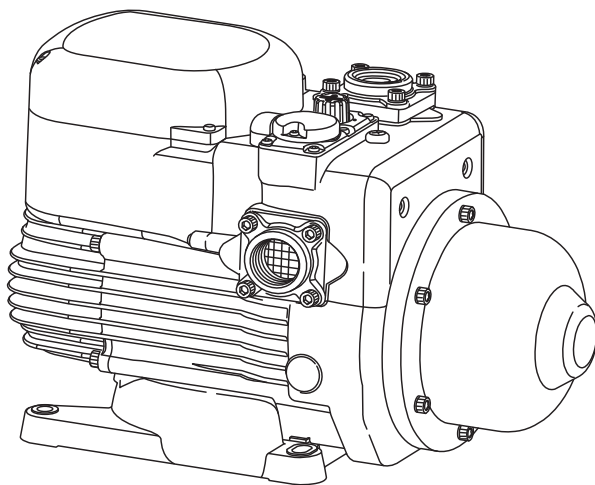

Model: WQ200B / WQ400B / WQ800B

To ensure safe and proper use, please read this instruction before operation.

ISO 9001 Certified    WALRUS PUMP CO., LTD.



# WQ\_B Series Instruction Manual

Before installing your new system, please study all instructions carefully, as the warranty does not cover failures caused by incorrect installation and operation.

## 1. Product

The WQ\_B series is designed to pump non-aggressive water or water not containing solid particles.

## 2. Operating Conditions:

1. Ambient temp.: Max. +40°C (104°F)
2. Liquid temp.: +4°C (39°F) ~ +40°C (104°F) Max.
3. System pressure: Max. 8.5kg/cm<sup>2</sup> (121 PSI)
4. Relative humidity: Max. 85% (RH)

## 3. For New Pump Installation



The pump has hot surface on the motor. It must be installed so that persons cannot accidentally come into contact the hot surface.

3.1 Install union to inlet and outlet piping prior to installing them to pump flanges. (See Fig. 1).

3.2 The pump foundation should be rigid enough to absorb any vibration from the motor, and the pump should be securely bolted to the foundation.

3.3 Please provide an adequate draining system to avoid damage in case of leakage, mainly when installed indoors. When it is installed outside, it should be covered by weather-proof and well-ventilated housing.

3.4 The pump and all piping must be protected from freezing. When the pump is exposed to a temperature less than 0°C (32°F), remove it to a heated area.

3.5 Connect the suction pipe to the side and discharge the pipe on the top. (See Fig. 2)

3.6 Regular maintenance requires opening the prime cover to access the check valve. DO NOT apply any bonded material (such as silicon, glue, etc.) to seal the chamber cover. (See Fig. 3)

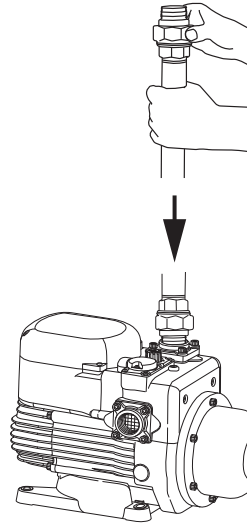

Fig. 1

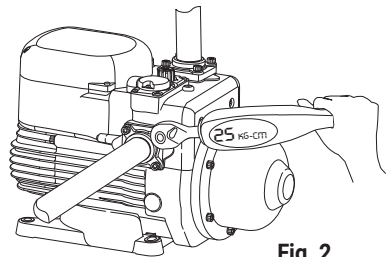

Fig. 2

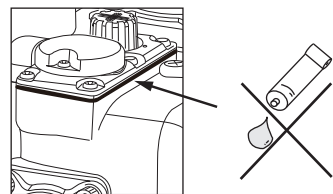

Fig. 3

## 4. Piping

- 4.1 The suction line should be installed as short and straight as possible, with a minimum of bends. The internal diameter of the suction pipe must be equal to or greater than the ports of the pump.
- 4.2 The connection between the suction line and pump must be airtight, and the suction pipe must be positioned, so it has an upward slope to the pump (thus avoiding the formation of air pockets).
- 4.3 If the water supply may contain solid particles, such as leaves and sand, a filter should be installed on the suction line.
- 4.4 If the hose is used as the suction pipe, it must be non-collapsible.
- 4.5 To minimize pressure drop, the discharge pipe should be at least the same size as the pump's discharge port.
- 4.6 For long suction pipes or high suction lifts over 4 m, the suction pipe should be of greater diameter than the suction port.
- 4.7 Ensure all connections are completely sealed using thread tape only.

## 5. Connections to Water Source

### 5.1 Flooded Suction-from Well System

With gravity feed to the pump, there are no special adjustments to be made. See Fig. 4 below for recommended layout. Simply make necessary plumbing connections and apply power. The pump is ready to use. (There are water outlets on the vertical and horizontal planes, directions use them as needed.)

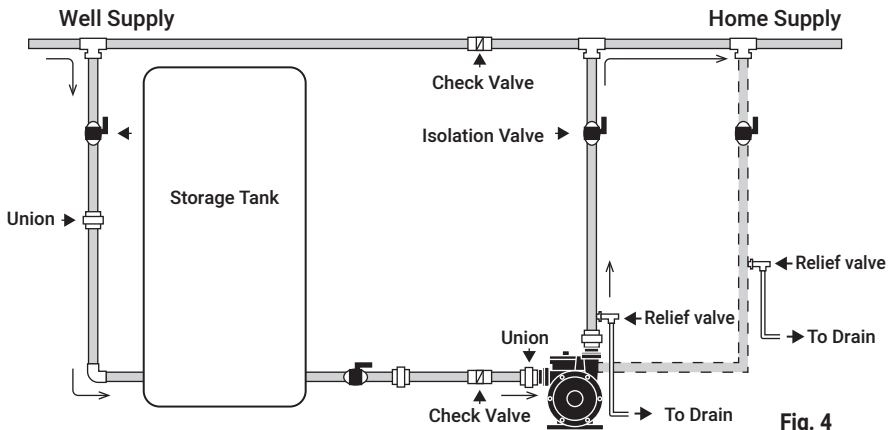

Fig. 4

## 5.2 Flooded Suction-from the city water supply.

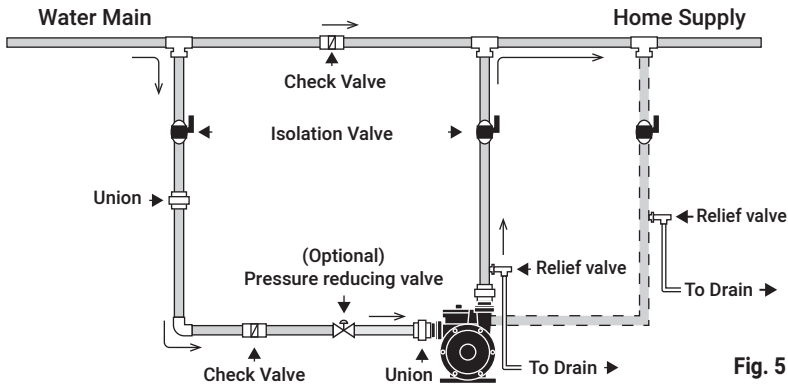

Fig. 5

Directly applied city pressure can exceed pump operating pressure and damage the pump. The max inlet pressure should not exceed 3.5 kg/cm<sup>2</sup>. Any greater incoming pressure is required to install a pressure-reducing valve on the suction side of the pump. In some areas where local codes restrict maximum home pressure, a pressure-reducing valve is also required on suction to lower the inlet pressure. The chart below shows the applicable settings for the pressure reducing valve:

Local code limits for home pressure	Pressure reducing valve setting (kg/cm <sup>2</sup> )		
	WQ200B	WQ400B	WQ800B
No limit	3.5	3.5	3.5
6.3 kg/cm <sup>2</sup>	3.5	3.2	2.8
5.6 kg/cm <sup>2</sup>	3.2	2.5	2.1

## 5.3 Suction Lift-below groundwater sources

This connection does not require any adjustment. Whenever the installation position of the pump is higher than 1m above the lowest water level, a foot valve must be installed on the end of the suction pipe.

## 6. Warning

The pump is not designed for continuous operation under low discharge flows such as slow-closing float valves slow running taps. Under this application, please install an extra tank (typically 2-3 gallons) to avoid “cycling”. (Fig. 6)

Please set the tank pressure the same as the pump pressure tank pressure. Leaking discharge lines and leaking taps will damage the unit by causing the pump to start and stop repeatedly.

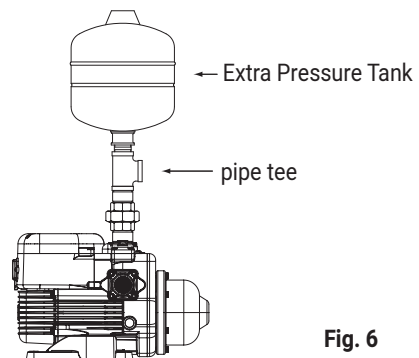

Fig. 6

**Note:** Optional external water pressure tank can be used to decrease the pump system's on/off cycle rate, which can extend the life of the pump.

## **7. Installation Guide**

- 7.1 This pump appliance is not intended for use by persons (including children) with reduced physical, sensory or mental capabilities or lack of experience and knowledge unless they have been given supervision or instruction concerning use of the pump appliance by a person responsible for their safety.
- 7.2 Please follow the wiring diagram for power distribution, and install a non-fuse breaker to prevent the motor from burning or catching fire.
- 7.3 Please install earth leakage circuit breaker and grounding to ensure safety.
- 7.4 The installation location must be protected from rain and direct sunlight, as well as install the pump near a drain. The diameter of the drainage holes must be larger than 1.5 inches and more than enough to drain the leaked water to avoid water puddling.
- 7.5 Do not install in limited space, poor drainage, ceiling, carpeted, or near electrical equipment location to prevent leakage damaging decoration or electrical facilities.
- 7.6 To prevent the impeller from stuck and damage. Please avoid any foreign object entering the pump, especially metal particles and PVC glue when piping.
- 7.7 Metal pipes are required for the outlet pipeline. Do not use PVC or plastic pipes for the outlet pipeline to prevent the pipes from deforming and rupturing due to excessive pressure or abnormal liquid temperature. To reduce pipe damage and noise, please install the inlet pipes with the same diameter as the pump outlet.
- 7.8 When the pump work with a water heater, high pressure will be generated due to hot water vapor. Please install a pressure-relief valve on the outlet pipeline to protect the pump for safety.
- 7.9 Do not stack flammable materials around the installation site to avoid catching fire.
- 7.10 To make the pump run smoothly, please fasten the pump to a solid horizontal foundation. If the pump is installed outdoors, it is recommended to purchase a special protective cover from our company.
- 7.11 The pipes and joints must be properly sealed. Leakage at the outlet will cause the pump to start frequently and fault. Poor sealing of the suction pipes will cause the pump to lose suction ability and dry-run. Do not install the breathing tube on the inlet. The inlet breathing tube may cause the pump to inhale air and dry-run. If the pump dry running for a while, the mechanical seal will be damaged, and the water temperature will be raised. Furthermore, the pipes will be deformed or ruptured caused of high water temperature.
- 7.12 The pump should be installed as close to the water source as possible. Long suction piping will reduce the efficiency of the pump.
- 7.13 The pump is equipped built-in non-return valve. There is no need to install a foot valve on the inlet pipeline, which will decrease the flow rate. If the inlet side adopted a negative pressure pumping method, a foot valve must be installed on the inlet to prevent the suction operating fault.
- 7.14 Turn off the power during water shortage or water source providing failure.

## 8. Electrical Connection



This mark located outside the connection box is an electrical hazard warning.

1. Ensure the mains voltage is the same as the value shown on the motor plate and that the pump is safely connected to the ground/earth.

## 9. Wiring Diagram

### WARNING:

Risk of electric shock-This pump has not been investigated for use in swimming pools or marine areas.

To reduce the risk of electric shock, connect only to a properly grounded, grounding-type receptacle.

Before the operation, please ensure the voltage is correct and the circuit breaker and grounding connectors are all connected in accordance with local regulations.

### Single-phase power supply

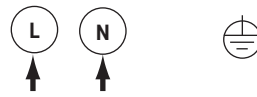

Input power

Grounding

Fig. 7

## 10. Starting

- 10.1 Before starting, the pump must be primed. For installation with no inlet pressure, please follow the procedure as shown in Fig. 8. (There are water outlets in both vertical and horizontal directions, please use than according to your needs.)

### a. Remove the filling plug

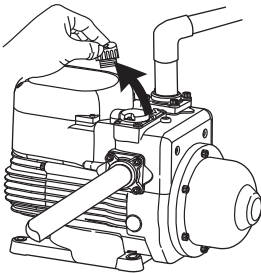

### b. Fill water in chamber

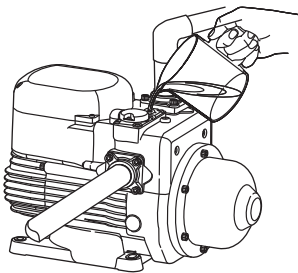

### c. Replace the filling plug

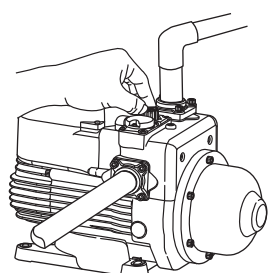

Fig. 8

- 10.2 For installation with inlet pressure, remove the priming plug and allow the water to flow into the priming chamber until all air is expelled.
- 10.3 The priming procedure should be repeated until all air is expelled and the pump delivers a full stream of water without air bubbles.
- 10.4 The pump must always be checked for prime if not used for a prolonged period. It is imperative to fill the pump with liquid before the operation as dry running causes irreparable damage to the mechanical seal.

## 11. Precautions

- 11.1 The pump should be shut down and the trouble corrected if the pump is running at speed and found to have any of the following problems:
- No liquid discharged-Not enough liquid discharged.
  - Excessive vibration-Motor runs hot.
- 11.2 Do not allow the pump to continually start and stop (cycling) as this will reduce the motor life.
- 11.3 Cycling can occur on pressure units when the pressure tank pre-charge drops or when there is a leak in the discharge plumbing.

## 12. Operation and Service

- 12.1 Please install the pump in a dry and ventilating environment, and leave enough space for service and maintenance access. The installation site with safety concerns we cannot provide maintenance services.
- 12.2 Do not operate the pump either with no water supply or other liquids than clean water.
- 12.3 The pump does not require maintenance under normal use, but please check the pump regularly. If the following situations occurred, please immediately notify our service team for inspection and maintenance services:
- There is leakage or unknown water stains around the pump, mechanical seal, and pipes. (Mechanical seal is a consumable part, and the degree of wearing depends on the operating environment or total running time)
  - The water pressure is unstable when the tap is turned on.
  - There is abnormal noise or heat when the pump is running.
  - Whether the pump runs normally when the tap turns on and off. (The control switch is a consumable part, and the degree of wearing depends on the operating environment or total running time)
- 12.4 Operation before pump operation:
- When the pump is started up for the first time, or it has not been used for a period of time. Place a screwdriver through the backward cover against the center shaft at the motor end, remove the rubber cover at the motor backward cover, and place a screw, and against the center shaft at the motor end, and turn it clockwise to see if the rotor spins freely.
  - Do not start the pump until it has been filled with water.
  - Before turning on the power supply, please confirm whether the power supply voltage is consistent with the specifications of the pump, and install a non-fuse breaker, earth leakage circuit breaker, and grounding to avoid electric shock.
  - Power on after the final checks

## 13. Operation and Maintenance

- 13.1 Diagnosis of the pump operation:
- There are 3 indicator lights on the terminal box-Power (Green), Failure (Red), and On (Yellow). The diagnosis of the pump operating condition is as below:
- (1) Power (Green): It is always on when connected to power.
  - (2) On (Yellow): Turns-on, when the tap is open, indicates normal operation.
  - (3) Failure (Red): Turns-on, when the tap is open, indicates the pump is run dry.
  - (4) On (Yellow): Turns on intermediately when the tap is closed indicates pipe leak.



- 13.2 Periodically check the condition of the check valve and strainer (if used).
- 13.3 If the pump is inactive for long periods, it should be rinsed thoroughly with clean water, then drained and stored in a dry place. It has to be re-primed before start-up.
- 13.4 If the pump shaft is seized up after periods of inactivity, please place a screwdriver from the motor end to rotate the shaft. It should free the pump shaft. (See Fig. 9) If this does not remedy the problem, the unit will need dismantling.

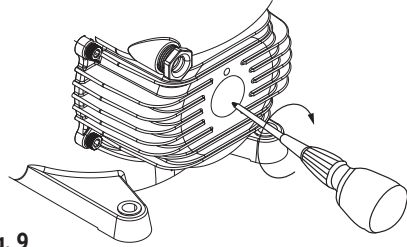

**Fig. 9**

- 13.5 Pressure tank air charge should be checked at regular intervals of every 6 months and after the pump has not been used for a prolonged period. To check the Tank pressure, turn off the power, open the tap on the discharge line to release pressure from the pump, unscrew the black plastic cover and place a pressure gauge on it as shown in Fig 10.

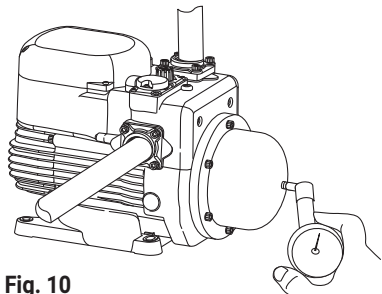

**Fig. 10**

Pressure should be adjusted to the original pre-charge as follows:

Model	50Hz
WQ200B	0.8 Kg/cm <sup>2</sup>
WQ400B	1.0 Kg/cm <sup>2</sup>
WQ800B	1.0 Kg/cm <sup>2</sup>

13.6 When the flanges are removed for maintenance or any reason, please follow the following instructions for installation:

a. Place the gasket to the flanges

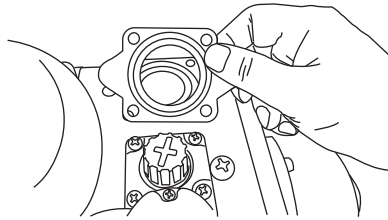
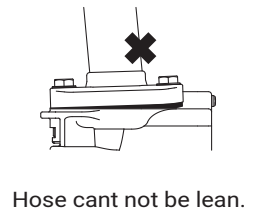
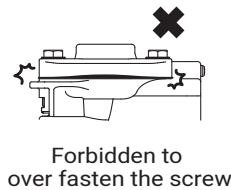
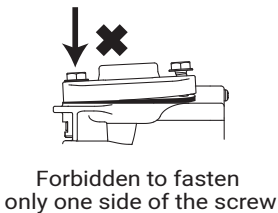
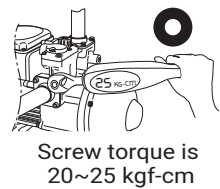
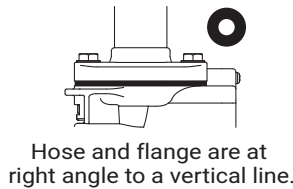
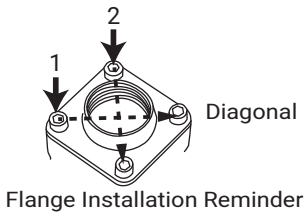

Fig. 11

b. Install 4 screws to the flange and DO NOT tighten up at this time. When all 4 screws are in place, tighten them diagonally onto the flange. DO NOT overtighten (recommended torque is 20~25 kgf-cm)



c. Install inlet and outlet pipings to the unions and then connect them to pump flanges.

13.7 Please plug off when it lacks water supply or the pump is not in use for a long time.

13.8 Maintenance precaution: When reinstalling the pressure tank, manually rotate the screws two turns into the threads before using electric tools to prevent stripped threads.

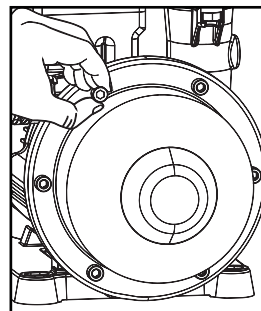

Fig. 12

## 14. Flooded Suction Performance Table

### WQ200B

Inlet pressure (Kg/cm <sup>2</sup> )	Flow rate				
	11.4 Lpm	22.7 Lpm	34.1 Lpm	45.4 Lpm	56.8 Lpm
0.7	2.7	2.3	1.9	1.5	1.0
1.4	3.4	3.0	2.6	2.2	1.7
2.1	4.1	3.7	3.3	2.9	2.4

### WQ400B

Inlet pressure (Kg/cm <sup>2</sup> )	Flow rate						
	11.4 Lpm	22.7 Lpm	34.1 Lpm	45.4 Lpm	56.8 Lpm	68.1 Lpm	79.5 Lpm
0.7	3.0	2.5	2.5	2.2	1.8	1.5	1.0
1.4	3.7	3.2	3.2	2.9	2.5	2.2	1.7
2.1	4.4	3.9	3.9	3.6	3.2	2.9	2.4

### WQ800B

Inlet pressure (Kg/cm <sup>2</sup> )	Flow rate									
	11.4 Lpm	22.7 Lpm	34.1 Lpm	45.4 Lpm	56.8 Lpm	68.1 Lpm	79.5 Lpm	90.8 Lpm	102.2 Lpm	113.6 Lpm
0.7	3.4	3.3	3.2	3.1	3.0	2.8	2.7	2.4	2.1	1.7
1.4	4.1	4.0	3.9	3.8	3.7	3.5	3.4	3.1	2.8	2.4
2.1	4.9	4.7	4.6	4.5	4.4	4.2	4.1	3.8	3.5	3.1
2.8	5.6	5.4	5.3	5.2	5.1	4.9	4.8	4.5	4.2	3.8

## 15. Noise level

The noise level of the pump is less than 70dB(A) of sound pressure level according to ISO 3746, the uncertainty is 4dB(A).

## 16. Frequently Asked Questions:

### 16.1 What causes the WQ\_B to start?

The WQ\_B has a built-in pressure switch and internal flow switch. Each of these can turn the pump on depending on water consumption. The pump will start when:

- The pressure is BELOW the pressure switch activation point. OR
- The flow rate is greater than 2.6 LPM.

The preset activation point for each model is provided in the pump specifications.

### 16.2 What causes the WQ\_B to stop?

The flow switch is designed to stop the WQ\_B pump automatically when the flow drops to below 2.6 LPM. After the pump is shut off, the motor will stop in 6 seconds for the WQ\_B series. In addition, the WQ\_B will be turned off in the event of a dry-run or over-temperature (trip at 55°C) alarm.

16.3 What is the purpose of the built-in pressure tank?

The pressure tank comes from the factory pressurized at approximately 1.4-1.8 Kg/cm<sup>2</sup> (with the pump pressure at zero). It is designed to minimize motor startup due to small flow demand or minor leaks of the pipeline.

WQ200B: 1.4 Kg/cm<sup>2</sup> (20 psi)

WQ400B: 1.6 Kg/cm<sup>2</sup> (22 psi)

WQ800B: 1.8 Kg/cm<sup>2</sup> (25 psi)

16.4 How is the dry-run and cycling condition determined and the protection provided?

The dry-run is defined when the motor is running, and the flow rate is less than 1.1 LPM and when pressure is less than the pressure switch setting. The protection is provided: When the pump is run dry 1 minute, it will automatically shut off for 10 minutes and then attempts to restart. When all 3 attempts are failed, the pump will rest for 1 hour and then attempts to restart. This protection mode will be repeated until the water supply is back to normal.

In case the pump is cycling (on-and-off repeatedly) due to small flow (less than 1.1 LPM), air pocket in the system, air loss in the pressure tank or leak in the pipeline, the protection is provided:

The pump will run for 6 seconds and stop for about 3 seconds. When the cycling mode repeats 15 times consecutively, the pump will rest for 1 hour. Then protection mode will start again until the problem is corrected.

**Note: The pump can be reset anytime by removing the power plug.**

16.5 What is the maximum inlet pressure allowed in the WQ\_B?

The maximum internal system pressure allowed for WQ\_B is 8.5 Kg/cm<sup>2</sup>. When added to the WQ\_B pressure, the maximum inlet pressure must not exceed 8.4 Kg/cm<sup>2</sup>.

Additionally, suppose inlet pressures exceed the built-in pressure switch activation point (1.4-1.8 Kg/cm<sup>2</sup> factory de fault). In that case, the pressure switch will be unable to function, and the ability to turn the WQ\_B on at low flow rates will be lost. In this situation, only the flow switch will be able to turn the WQ\_B on at flow rates above 2.6 LPM.

## 17. Dimensions: (mm)

WQ200B/WQ400B/WQ800B

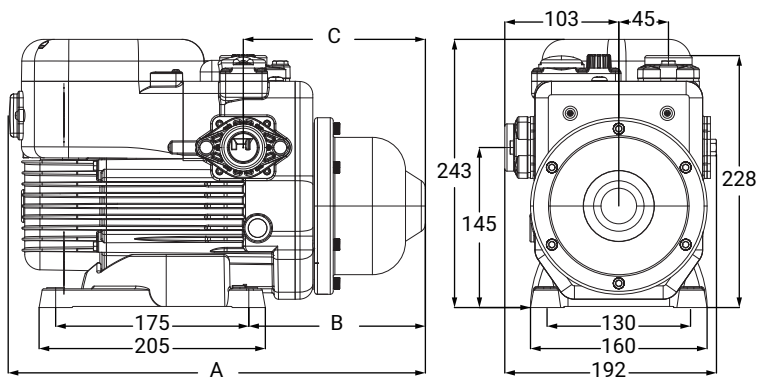

## 18. Specification

Model	Cycle (Hz)	Dimensions(mm)		
		A	B	C
WQ200B	50	378	160	165
WQ400B	50	378	160	165
WQ800B	50	404	167	172

## 18. Troubleshooting



**Before starting work on the pump, ensure that the electricity supply has been switched off and that it cannot be accidentally switched on.**

Problem	Cause	Remedy
1. Pump does not start	a. No power supply	Connect the electricity supply
	b. Too low/high voltage	Check if the supply voltage is within $\pm 10\%$
	c. No water consumption	Open a tap
	d. Seized-up pump	Place a screwdriver against the shaft end of the motor to check if the rotor will spin freely, and contact your pump supplier.
2. Pump cuts out during operation	a. Seized-up pump	Same as above
	b. Overloaded motor	Turn off the power supply and restart or contact your pump supplier.
	c. Poor water supply	Check if the pump suction inlet is blocked.
	d. The protection for pump dry run or cycling is activated.	Check the detailed information per XII (Frequently asked questions).
3. Pump starts when no water is consumed	a. Existing pipe is leaking	Fix the leakage.
	b. Defective check valve	Clean or replace a new one.
	c. Pipe suck in air.	Check the suction pipe and water supply.
4. Pump starts and stops too frequently	a. Leakage in the suction pipe or air in the water.	Check the suction pipe and water supply.
	b. Discharge flow is too low.	Set your tap on a higher water flow.
5. Electric shock	a. Defective ground connection	Correct the ground connection.
6. Pump does not stop when water is not consumed	a. Poor water supply or air suck in.	1. Turn off the power supply and open the refilling plug to release the air. Then restart. 2. In case of long suction pipes, turn off the power and ensure the water supply is adequate.
	b. Defective check valve.	Clean or replace with a new valve.
7. Pump runs normal but with very low discharge flow	a. Poor water supply	Check if the water supply is adequate and if the suction pipe is blocked.
8. Green and Yellow lights turn on when the tap is open		The pump is in normal operation
9. Green and Red lights turn on when the tap is open	The pump is in dry run	Shut off the power, and check the water source
10. Green light is on, and the Yellow light is turned on intermediately when the tap is closed.	The pump is cycling most likely because of a pipe leak.	Fix the pipe leak

# Limited Warranty

Products manufactured by Walrus Pumps Co (Walrus) are warranted to the first user only to be free of defects in material and workmanship for a period of 3 years from the date of installation, but no more than 24 months from the date of shipment. Walrus' liability under this warranty shall be limited to repairing or replacing at our election, without charge, FOB Walrus' distribution center or authorized service agent. Walrus will not be liable for any cost of removal, installation, transportation, or any other charges that may arise in connection with the warranty claim.

The warranty period commences on the date of the original purchase of the equipment. Proof of purchase and installation date, failure date, and supporting installation data must be provided when claiming repairs under warranty.

This warranty is subject to due compliance by the original purchaser with all directions and conditions set out in the installation and operating instructions. Failure to comply with these instructions, damage or breakdown caused by fair wear and tear, negligence, misuse, incorrect installation, inappropriate chemicals or additives in the water, inadequate protection against freezing, rain or other adverse weather conditions, corrosive or abrasive water, lightning or high voltage spikes or through unauthorized persons attempting repairs are not covered under warranty.

Walrus will not be liable for any incidental or consequential damages, losses, or expenses, arising from installation, use, or any other causes. There are no express or implied warranties, including merchantability or fitness for a particular purpose, which extends beyond those warranties described or referred to above.

Certain states do not permit the exclusion or limitation of incidental or consequential damages or the placing of limitations on the duration of an implied warranty; therefore, the limitations or exclusions herein may not apply. This warranty sets forth specific legal rights and obligations; however, additional rights may exist, which may vary from state to state.

Supersedes all previous publications



**WALRUS**  
PUMP



[walruspump.com](http://walruspump.com)

**WALRUS PUMP CO., LTD.**