



# WALRUS

*IC Series*

## ***Duplex Booster System Instruction Manual***



ISO 9001 Certified

---

**Walrus Pump Co., Ltd.**

Congratulations on your purchase of Walrus IC Series Inverter Control System. Please read all instructions carefully before installing your new system. The system has been designed and manufactured to give trouble free, reliable operation. Upon receiving, please check the following:

- a. No shipping damage.
- b. Product specs match name plate data (such as pressure, voltage, HP, etc).

## **I. Functions and Features**

- a. The system provides constant pressure despite varying consumption.
- b. Pump will automatically shut off when it is in dry run.
- c. The pump will compensate the pressure loss due to the leak in the system.
- d. Available for Simplex and Duplex.
- e. Pump will start when the tap is open and shut off when the water flow is stopped .

## **2. Installation**

### **2.1 Installation site**

- a. Choose a site dry and with good ventilation. The ambient temperature is at 4°C-40°C.
- b. Recommend to install inside. If you have to install outside, please provide a pump house with water proof and frost free to protect from weather
- c. No vibration and unusual electrical surge.
- d. Easy access for maintenance.

### **2.2 Cautions of installation**

- a. Avoid sucking in any solid particles; especially bounding glue or chips from pipe work.
- b. Make sure the power supply is correctly connected at 1-phase 220V±10%, 3-phase 220V±10%, 3-phase 380V±10%.
- c. Never run pump dry; and keep the pumped liquid below 40°C. Make sure your system is always connected to an adequate, reliable source of clean water.
- d. For your safety, be sure the GFCI (Ground Fault Circuit Interrupter) is in your system and grounding is properly connected to prevent from electric shock.



When using a regular GFCI (Ground Fault Circuit Interrupter), please select a current sensor with sensitivity of 200mA, and not less than 0.1-second detection time to avoid nuisance tripping. When using a designated GFCI for AC motor drive, please select a current sensor with sensitivity of 30mA or above.

### 3. Control Panel

The system status is displayed on the built-in “controller”.



The built-in controller

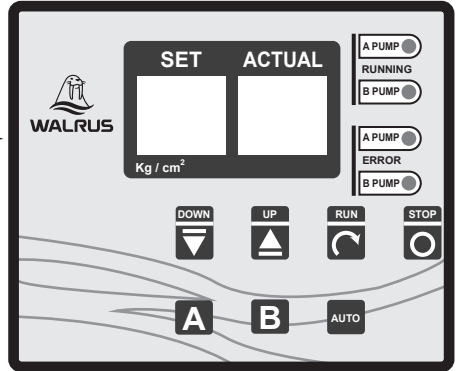

#### Function of the Keypad:

##### SET



The number in the screen indicates the set pressure in kg/cm<sup>2</sup>.

##### ACTUAL



The number in the screen indicates the actual operating pressure in kg/cm<sup>2</sup>.



Both lights on to indicate two pumps are both running.

One light on to indicate either Pump A or Pump B is running.



Both lights on to indicate both pumps malfunction.

One light on to indicate either Pump A or Pump B is malfunction.



Press to reduce pressure (0.1-9.9)



Press to increase pressure (0.1-9.9)



Press to turn on the pump



Press to force the pump to stop. Under normal operation, the pump will stop automatically when the tap is closed.

It is also the new setting memory key.



Press to operate Pump A only.



Press to operate Pump B only.







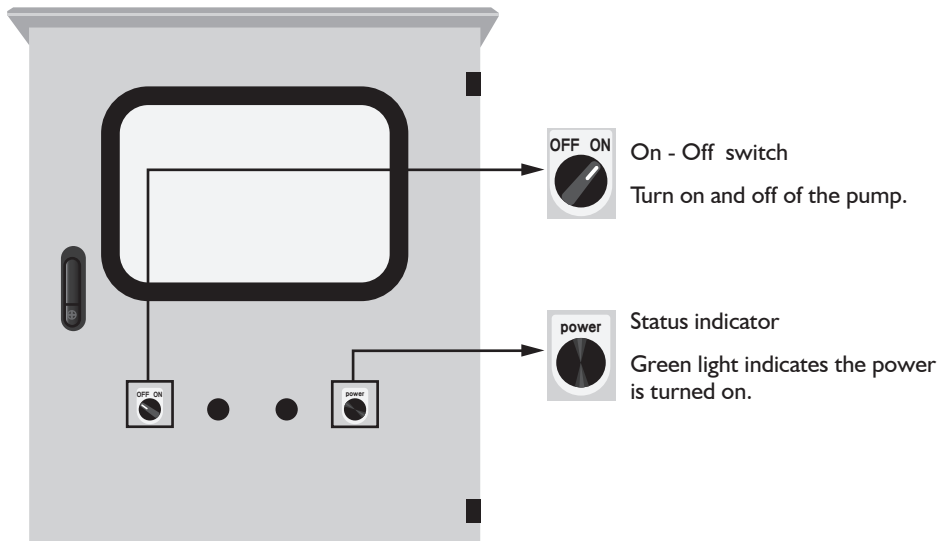





Press to run the system automatically. It will enable the system to run one pump or two pumps automatically depending on water requirement.



## Control Box Panel



## Adjustment of Preset Pressure

1. When you start up the pump, the SET pressure indicates the factory default pressure. It is also the max. constant pressure the pump will work. It can be set lower by pressing  until the SET screen shows the number you desire, and then press  to memorize the new setting.
2. You can not increase the SET pressure unless you have positive incoming pressure from your water source. For example, you have 1 kg/cm<sup>2</sup> incoming pressure and the default pressure is 3 kg/cm<sup>2</sup>, you can adjust the SET pressure up to 4 kg/cm<sup>2</sup> as max. Make sure your positive incoming pressure is very stable because the pump performance will be affected once your incoming pressure is fluctuated.
3. To increase SET pressure, please press  to the number you desire, and then press  to memorize the new setting.
4. Select to run Pump A or Pump B only
  - . For maintenance or repair, it can be set to run only one pump.
  - . Press Pump  or .
  - . Press  to memorize the new setting.
  - . Press  to start the system.
5. Set back to AUTO mode
  - . Only necessary after the system is set to run at Pump A or B.
  - . Press .
  - . Press  to memorize it.
  - . Press  to start the system.
6. For other adjustment, please contact us for more information.

### Remarks:

- . After finishing any adjustment of the above, please be sure to press  to default the new setting. If you do not press , the pump will resume the previous setting when the power turns off.
- . When the indicator display “”, the pump is in dry run and it will be shut off automatically. The default is set to stop for 1 hour and the pump will attempt to run 1 minutes and stop for 1 hour. The stop-and-run cycle will be continued until the water supply is normal. It is highly recommended to shut off the pump when the water supply has problem as continue to run the pump dry will cause serious damage.

## 4. Start Up the Pump

4.1 Connect the power.

4.2 Check if the voltage and wiring are correct before you switch on the pump. The voltage should be kept at  $\pm 10\%$  of the rated voltage on the nameplate.

### 4.3 Priming

Do not start the pump until it has been primed. Follow the following priming instruction:

4.3.1 Booster systems and systems where the liquid level on the suction side is above the pump inlet:

4.3.1.1 Close the isolating valves either side of the pump.

4.3.1.2 Remove the priming plug, fig. 1.

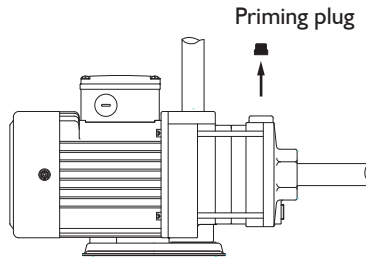

**Fig. 1**

4.3.1.3 Slowly open the suction valve and keep it open until a steady stream of liquid runs out the priming port.

4.3.1.4 Close the valve, replace the priming plug and tighten it.

4.3.1.5 Open the suction valve.

4.3.1.6 Turn ON to start the pump. The pump will operate at the auto mode.

4.3.1.7 Make sure the motor runs the same direction as the rotating direction sticker (on the motor fan cover).

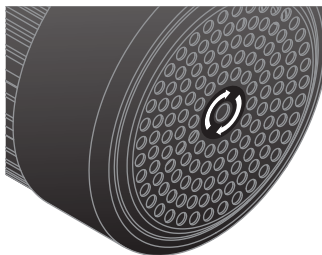

4.3.1.8 Slowly open the discharge valve until it is fully open.

4.3.2 Pumping from tanks and wells where the liquid level on the suction side is below the pump inlet:

4.3.2.1 Close the discharge isolating valve.

4.3.2.2 Remove the priming plug, fig. 2.

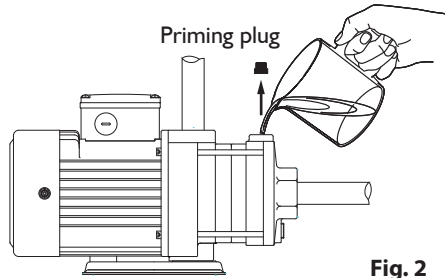

4.3.2.3 Pour water through the priming port. Make sure that the suction pipe and pump are completely filled with liquid and vented.

4.3.2.4 Replace the priming plug and tighten it.

4.3.2.5 Turn ON to start the pump. The pump will operate at the auto mode.

4.3.2.6 Make sure the motor runs the same direction as the rotating direction sticker (on the motor fan cover).

4.3.2.7 Slowly open the discharge valve until it is fully open.

4.4 If there is no discharge flow after a few minutes, please turn off the pump and repeat the Process of 4.3 Turn the pump on and off several times until it is working normally.

## 5. Trouble Shooting

### 5.1 For pump and motor: (Before proceeding any action, please switch off the power.)

Cause	Remedy
5.1.1 Motor does not run.	<ul style="list-style-type: none"> <li>a. Check if voltage is correct.</li> <li>b. Check if water supply is adequate.</li> <li>c. Check if rotor spins freely.</li> <li>d. If the problem is unsolved, please contact our distributor or us.</li> </ul>
5.1.2 Motor keeps running when water flow is stopped	<ul style="list-style-type: none"> <li>a. Check if faucet is completely shut off.</li> <li>b. Check if there is any leak in the system.</li> <li>c. Check if check valve function normally.</li> <li>d. Check if water supply is adequate.</li> </ul>

### 5.2 For controller:

Display	Description	Remedy
AF	Error signal of inverter	Check if connection from controller to inverter is good.
□	Error of dry run or power being shut off	<ul style="list-style-type: none"> <li>1. Check if the water supply is adequate; otherwise, please switch off the power.</li> <li>2. Check if connection of the transducer is good.</li> <li>3. Check if the pump is in dry run protection mode. The default is to stop for 1 hour and the pump will attempt to run 1 minutes and stop for 1 hour. The stop-and-run cycle will continue until the water supply is normal. When the pump is for sure in dry run, it is required to STOP it and turn off the power.</li> </ul>



# 6. Wiring diagram

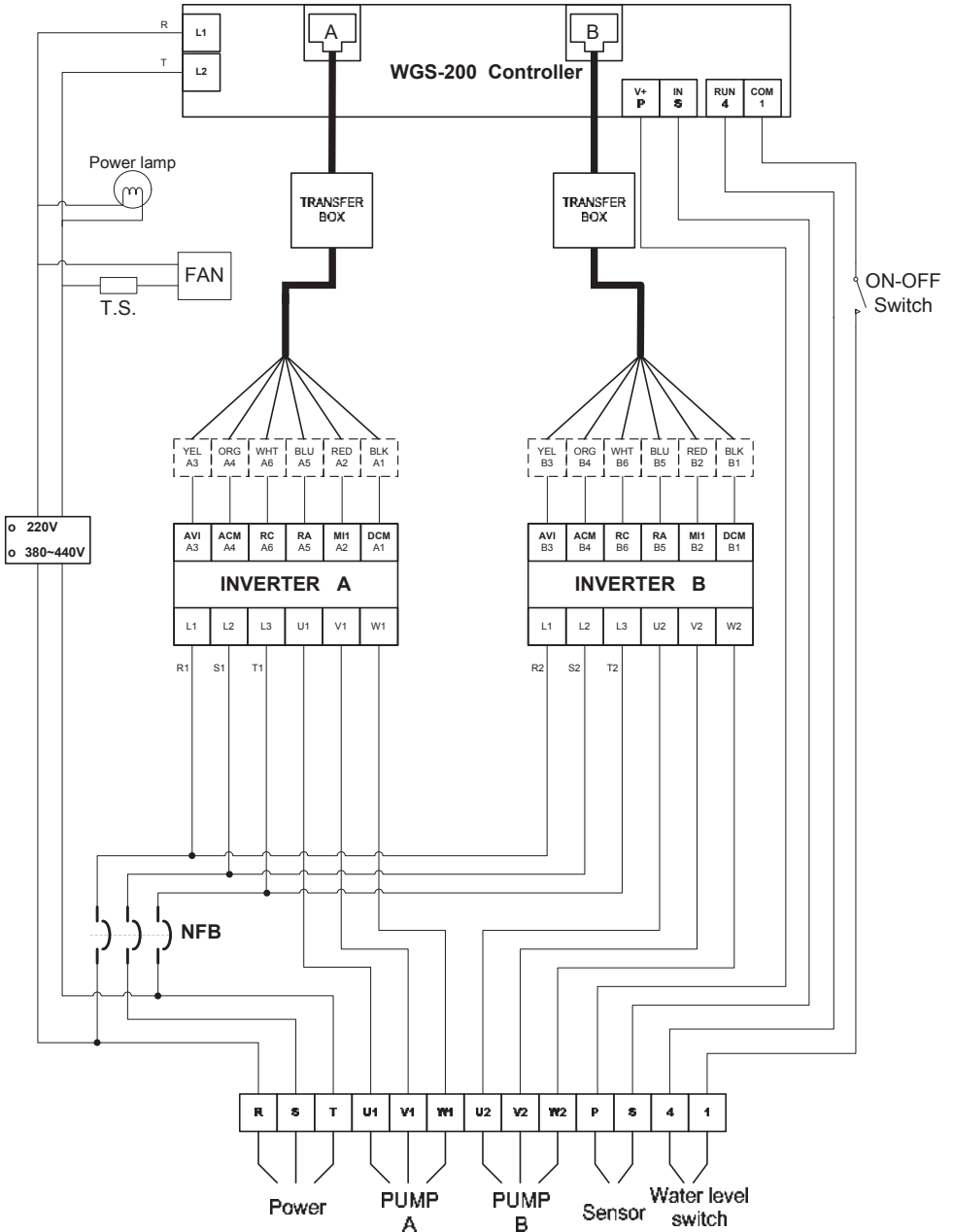

## 7 Parameter Settings

### 7.1 Controller parameter settings

code	function	Description	Set	Unit
0	P gain	P gain adjustment	6	
1	I gain	I gain adjustment	4	
2		HOLD	12	
3	water leakage compensation pressure	when turn off , the pressure is lower to compensated value, controller would start to run	3	0.1kg/cm <sup>2</sup>
4	turn off dectection	when inverter output frequency is lower than dectection , controller will stop output immediately.	153	
5	turn off dectection interval	can do turn off testing according to turn off dectection interval	100	0.1sec
6	turn off decreasing speed	can do turn off testing according to turn off decreasing speed	10	
7	pressure sensor spec	input use pressure sensor max. pressure vaule spec.	100	0.1kg/cm <sup>2</sup>
8		HOLD	-	
9	parallel waiting time	after inverter full output , when the pressure difference is over than0.2 bar, it would stop parallel running after waiting setting time	100	0.1sec
A	remote parallel wating time	after inverter output to zero, when the feedback value is over than the setting vaule, it would stop parallel running after wating setting time	100	0.1sec
B	alternating time	alternating time setting	5	hour
C	no water pressure detection	when pressure is lower than the detection , then contorller will enter to the no water detection mode	5	0.1kg/cm <sup>2</sup>
D	no water resting time	no water resting time setting	60	minute
E	no water detection time	no water detection time setting	60	second
F	pressure compensation adjust	pressure value compensation adjust setting		
H	power on option	0: terminal , 1 : key entering	1	
J	run option	0 : double pump( alternate ) 1 : single pump( parallel )	0	
L	alternating option	0: alternate at once , 1: alternate after turn off	1	
N	breakdown connection type	0 : NC , 1 : ON	1	
O		HOLD	0	
P		HOLD	0	

R	Stop speed value	HOLD	15	0.1kg/cm <sup>2</sup>
T	Positive negative Pressure value	A PUMP Do not check speed		A PUMP
U	Maxi Pressure value			kg/cm <sup>2</sup>
Y	Positive negative Pressure value	B PUMP Do not check speed		B PUMP

## 7.2 Inverter parameter settings

Parameter	Explanation	Settings	Factory Setting
00.02	Parameter Reset	9: All parameters are reset to factory settings (50Hz, 230V/400V or 220V/380V depends on Pr.00.12) 10: All parameters are reset to factory settings (60Hz, 220V/440V)	10
01.07	Output Frequency Upper Limit	0.1 to 120.0%	100.0
01.09	Accel Time I	0.1 to 600.0 sec	3.0
01.10	Decel Time I	0.1 to 600.0 sec	30.0
02.05	Line Start Lockout	0: Disable. Operation status is not changed even if operation command source Pr.02.01 is changed. 1: Enable. Operation status is not changed even if operation command source Pr.02.01 is changed.	0
04.13	Max AVI Voltage	0.0 to 10.0V	9.8

# Limited Warranty

Products manufactured by Walrus Pumps Co (Walrus) are warranted to the first user only to be free of defects in material and workmanship for a period of 12 months from date of installation, but no more than 24 months from date of shipment. Walrus' liability under this warranty shall be limited to repairing or replacing at our election, without charge, FOB Walrus' distribution center or authorized service agent. Walrus will not be liable for any cost of removal, installation, transportation or any other charges that may arise in connection with warranty claim.

The warranty period commences on the date of original purchase of the equipment. Proof of purchase and installation date, failure date, and supporting installation data must be provided when claiming repairs under warranty.

This warranty is subject to due compliance by the original purchaser with all directions and conditions set out in the installation and operating instructions. Failure to comply with these instructions, damage or breakdown caused by fair wear and tear, negligence, misuse, incorrect installation, inappropriate chemicals or additives in the water, inadequate protection against freezing, rain or other adverse weather conditions, corrosive or abrasive water, lightning or high voltage spikes or through unauthorized persons attempting repairs are not covered under warranty.

Walrus will not be liable for any incidental or consequential damages, losses, or expenses, arising from installation, use, or any other causes. There are no express or implied warranties, including merchantability or fitness for a particular purpose, which extend beyond those warranties described or referred to above.

Certain states do not permit the exclusion or limitation of incidental or consequential damages or the placing of limitations on the duration of an implied warranty, therefore, the limitations or exclusions herein may not apply. This warranty sets forth specific legal rights and obligations, however, additional rights may exist, which may vary from state to state.

Supersedes all previous publications



**WALRUS PUMP CO., LTD.**

Web: [www.walruspump.com](http://www.walruspump.com)