



WALRUS

TPHK Series

Immersible Pump

Instruction Manual

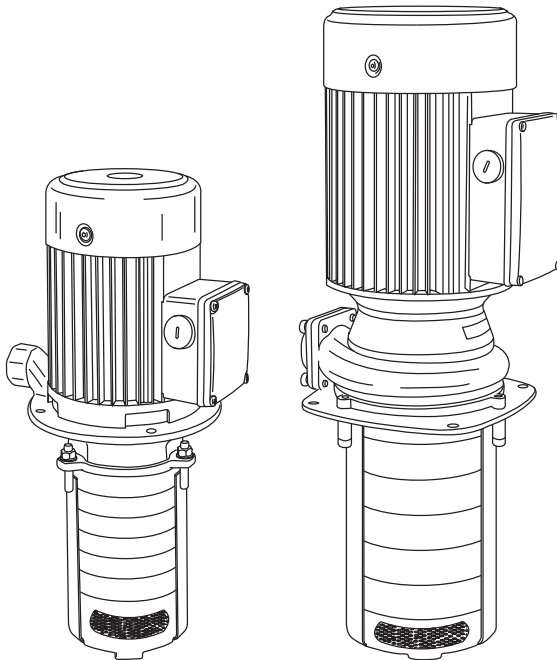

ISO 9001 Certified

WALRUS PUMP CO., LTD.

EC Declaration of Conformity

Manufacturer:

Walrus Pump Co., Ltd.

Address:

No.83-14, Dapiantou, Sanzhi Dist., New Taipei City 252, Taiwan

Declare that the machinery described:

Name : Water Pump

Model : TPHK Series

Conform to the following directive:

2006/42/EC—Machinery directive

2014/35/EU—Low voltage directive

2014/30/EU—EMC (Electromagnetic compatibility) directive

Refer to the following standards:

EN ISO 12100:2010

EN ISO 13857:2008

EN 809:1998+A1:2009

EN 60204-1:2006

EN 60335-1:2012

EN 60335-2-41:2003+A2:2012

EN 61000-6-2:2005

EN 61000-6-3:2007

R&D department manager: Kao Tien-chuan

Manager:

Kao Tien chuan



Please read this instruction manual carefully before installing your new system as failures caused by incorrect installation and operation are not covered by the warranty.

1. Application

- 1.1. The TPHK series is multi-stage centrifugal pump designed for industrial use, especially for machine tools.
- 1.2. The pump can not be used to transfer explosive liquids; such as gasoline, diesel oil or similar liquids. It is suitable to carry liquids such as water, coolant, low viscosity or other non-corrosive liquids.

2. Product Code Designation

The standard range of pumps includes complete impeller in chamber combinations. Upon request, a special length can be supplied by fitting empty intermediate chambers instead of standard chambers with impellers. The pump nameplate indicates the number of chambers and impellers fitted to the pump.

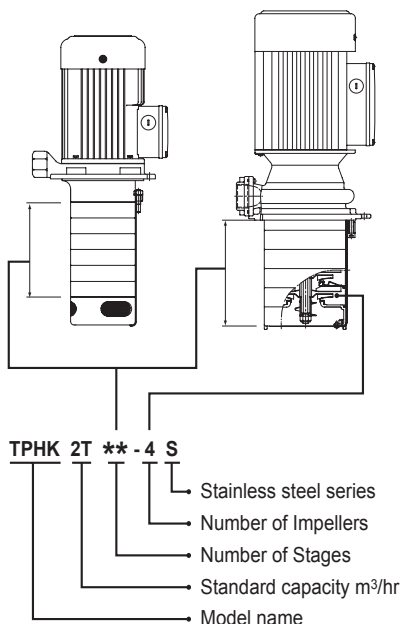

3. Operating Limits

1. Ambient temperature : Max. 40°C
2. Liquid temperature range: 0°C to 90°C
3. Operating pressure : Max. 10 kg/cm²
4. Submerged depth : Min. 40mm
5. Stainer Diameter: Ø2mm (TPHK2T,4T)
Ø3mm (TPHK8T,12T)
6. Particle Size: 2mm(TPHK2T,4T)
3mm(TPHK8T,12T)
7. Liquids(maximum content of solid particles in suspension 50g/m³)
8. Kinematical Viscosity: 32 cst (mm²/s)
9. Head: 50Hz : Up to 65M
60Hz : Up to 90M
10. Stops and restarts:

Input power[W]	times/hour
Below 3000	250
3000~5000	100

4. Installation



The pump has hot surface on the motor. It must be installed so that persons cannot accidentally come into contact with the hot surface.

4.1. Submerged Depth

To avoid dry running and damage the pump during operation, the minimum pump submerged depth is 40mm (1⁵/₈") as shown in Fig 1. In addition, the bottom of the pump suction inlet must be at least 25 mm (1") above the bottom of the tank.

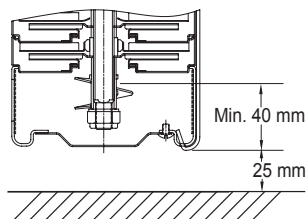

Fig.1

- 4.2. We recommend outlet should stay the same size as the original. If you narrow the pipe size, it will affect the performance of the pump.
- 4.3. The motor protector shall be installed by the user.

5. Electrical Connection



5.1 The electrical connection should be carried out in accordance with local regulations. Never make any connections unless the electricity supply has been switched off.



5.2. The electrical hazard warning mark is placed outside the connection box. Be careful.

5.3. Electrical data (voltage and frequency) are shown on the pump nameplate. Verify if these data match your electricity supply. A Residual current device (RCD, 30mA) should be installed and the grounding be properly connected for your safety.

5.4. Motors must be connected to a motor-protective circuit breaker which can be manually reset. Set the motor-protective circuit breaker according to the rated current of the motor. See nameplate.

5.5. Make electrical connection in accordance with connecting diagram located inside the connection box. The motor current must be within the rated amps range indicated on nameplate. Three phase motor requires a magnetic starter for safety.

5.6. For three phase motors, please check the correct direction of rotation of the pump on the motor fan cover. When seen from motor fan cover end, the pump should rotate clockwise. You can reverse the direction of rotation by interchanging any two of the incoming supply wires.

5.7. If the supply cord is damaged, it must be replaced by the manufacturer, its service agent or similiary qualified persons in order to avoid a hazard.

5.8. The user shall install a over-load protection device for the pump runing.

6. Start-up

Before starting the pump, make sure the following:

6.1. For three phase motors, verify if the

rotating direction is correct. It should be clockwise viewing from the motor fan cover end.

6.2. All piping joints are completely tight. Leakage in piping may cause the pump hydraulic loss.

6.3. The pump is filled with liquid.

6.4. The suction filter is not blocked by any foreign objects.

7. Operation and Maintenance



It is dangerous to operate the pump against a closed discharge outlet because it will cause extremely high liquid flow temperature and damage the pump in a few minutes.

7.1. Lubrication

The mechanical seal and shaft sleeves are lubricated by the pumped liquid.

7.2. Suction filter

Always keep suction filter clean and make sure it is not blocked by impurities.

7.3. Periodic checks

The following checks should be carried out periodically to ensure the normal operation.

7.3.1. Check the quantity of liquid and operating pressure.

7.3.2. Check there are no leaks on piping joints.

7.3.3. Check the tripping of the motor starter.

7.3.4. Check that all controls are functioned normally.

7.4. When pump is not in use for a period, it should be drained. For start up after long time inactivity please check if the impeller and mechanical seal are free. If they are locked up by sand, rust or something else please clean them up.

7.5. The pump must not be used to transfer explosive liquids. In systems with hot liquids (over 60°C), extra caution should be exercised to prevent from personal injury.

7.6. The pump should not be used to transfer toxic or contaminated liquids. Please carefully follow all instructions in the manual as Walrus may refuse to accept

the contaminated pump for servicing.

- 7.7. If the supply cord is damaged, it must be replaced by a special cord or assembly available from the manufacturer or its service agent.

8. Sound pressure level

Motor	dB(A)
TPHK2T ** - 1	<70
TPHK2T ** - 2	<70
TPHK2T ** - 3	<70
TPHK2T ** - 4	<70
TPHK2T ** - 5	<70
TPHK2T ** - 6	<70
TPHK2T ** - 7	<70

Motor	dB(A)
TPHK4T ** - 1	<70
TPHK4T ** - 2	<70
TPHK4T ** - 3	<70
TPHK4T ** - 4	<70
TPHK4T ** - 5	<70
TPHK4T ** - 6	<70
TPHK4T ** - 7	<70

Motor	dB(A)
TPHK8T ** - 2	<70
TPHK8T ** - 3	71
TPHK8T ** - 4	76
TPHK8T ** - 5	76

Motor	dB(A)
TPHK12T ** - 1	71
TPHK12T ** - 2	76
TPHK12T ** - 3	76

Above drawing shows the noise level while pump operated with closed outlet.

The tolerance of noise level is $\pm 3\text{dB(A)}$.

9. Wiring diagram

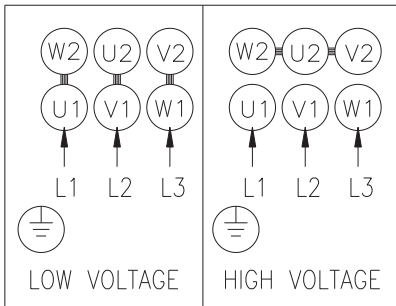

10. Fault finding

(Make sure electricity supply has been switched off before attempting to diagnose any fault)

Fault	Cause
10.1. Motor does not start	a. No electricity supply
	b. Fuses are blown.
	c. Motor overheating relay tripped.
	d. Defective magnetic contactors.
	e. Control circuit malfunction.
10.2. Motor cut out during operation.	a. Fuses blown or breakers tripped.
	b. Overheating relay tripped.
	c. Control circuit malfunction.
	d. Pump locked up by foreign objects.
10.3. Pumped capacity is not constant.	a. Pump impeller blocked by impurities.
	b. Insufficient liquid level in the tank. (See Sec. 4.1)
10.4. Pump runs but gives no liquid.	a. Suction filter blocked by impurities.
	b. Liquid level is too low (See Sec. 4.1)
	c. Incorrect rotating direction.

11. Dimensions TPHK 2T/4T

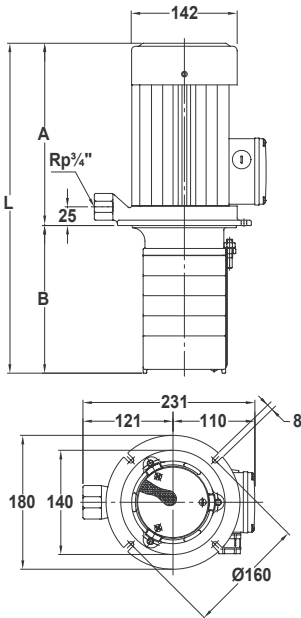

TPHK 8T/12T

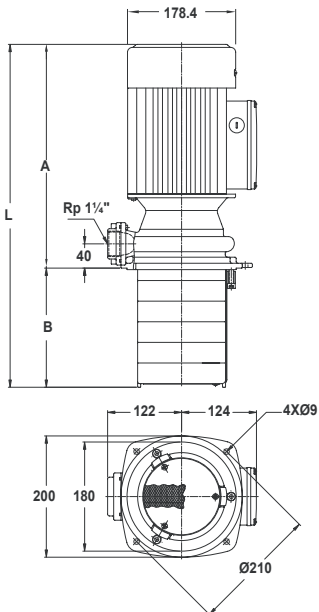

Model	A(mm)	B(mm)	C(mm)
	50Hz / 60Hz		
TPHK 2T 3 -1	205	145	350
TPHK 2T 8 -1	205	235	440
TPHK 2T 3 -2	205	145	350
TPHK 2T 5 -2	205	181	386
TPHK 2T 9 -2	205	253	458
TPHK 2T 3 -3	205	145	350
TPHK 2T 4 -3	205	163	368
TPHK 2T 5 -3	205	181	386
TPHK 2T 6 -3	205	199	404
TPHK 2T 8 -3	205	235	440
TPHK 2T11-3	205	289	494
TPHK 2T 4 -4	205	163	368
TPHK 2T 6 -4	205	199	404
TPHK 2T 5 -5	245	181	426
TPHK 2T 6 -5	245	199	444
TPHK 2T 6 -6	253	199	452
TPHK 2T 8 -6	253	235	488
TPHK 2T 9 -6	253	253	506
TPHK 2T10-6	253	271	524
TPHK 2T11-6	253	289	542
TPHK 2T 7 -7	253	217	470

TPHK 4T 2 -1	205	145	350
TPHK 4T 3 -1	205	172	377
TPHK 4T 2 -2	205	145	350
TPHK 4T 3 -2	205	172	377
TPHK 4T 4 -2	205	199	404
TPHK 4T 6 -2	205	253	458
TPHK 4T 3 -3	245	172	417
TPHK 4T 4 -3	245	199	444
TPHK 4T 5 -3	245	226	471
TPHK 4T 6 -3	245	253	498
TPHK 4T 8 -3	245	307	552
TPHK 4T 4 -4	245	199	444
TPHK 4T 5 -4	245	226	471
TPHK 4T 6 -4	245	253	498
TPHK 4T 5 -5	245	226	471
TPHK 4T 8 -5	245	307	552
TPHK 4T 6 -6	253 / 283	253	506 / 536
TPHK 4T 8 -6	253 / 283	307	560 / 590
TPHK 4T 7 -7	283	280	563
TPHK 4T 8 -7	283	307	590

TPHK 8T 6 -2	369	199	568
TPHK 8T 9 -2	369	298.5	667.5
TPHK 8T 3 -3	369	95.5	464.5
TPHK 8T 6 -3	369	199	568
TPHK 8T 9 -3	369	298.5	667.5
TPHK 8T 4 -4	369	130	499
TPHK 8T 6 -4	369	199	568
TPHK 8T 5 -5	369	164.5	533.5

TPHK12T 6 -1	369	199	568
TPHK12T 6 -2	369	199	568
TPHK12T 9 -2	369	298.5	667.5
TPHK12T 6 -3	369	199	568
TPHK12T 9 -3	369	298.5	667.5

Limited Warranty

Products manufactured by Walrus Pumps Co (Walrus) are warranted to the first user only to be free of defects in material and workmanship for a period of 12 months from date of installation, but no more than 24 months from date of shipment. Walrus' liability under this warranty shall be limited to repairing or replacing at our election, without charge, FOB Walrus' distribution center or authorized service agent. Walrus will not be liable for any cost of removal, installation, transportation or any other charges that may arise in connection with warranty claim.

The warranty period commences on the date of original purchase of the equipment. Proof of purchase and installation date, failure date, and supporting installation data must be provided when claiming repairs under warranty.

This warranty is subject to due compliance by the original purchaser with all directions and conditions set out in the installation and operating instructions. Failure to comply with these instructions, damage or breakdown caused by fair wear and tear, negligence, misuse, incorrect installation, inappropriate chemicals or additives in the water, inadequate protection against freezing, rain or other adverse weather conditions, corrosive or abrasive water, lightning or high voltage spikes or through unauthorized persons attempting repairs are not covered under warranty.

Walrus will not be liable for any incidental or consequential damages, losses, or expenses, arising from installation, use, or any other causes. There are no express or implied warranties, including merchantability or fitness for a particular purpose, which extend beyond those warranties described or referred to above.

Certain states do not permit the exclusion or limitation of incidental or consequential damages or the placing of limitations on the duration of an implied warranty, therefore, the limitations or exclusions herein may not apply. This warranty sets forth specific legal rights and obligations, however, additional rights may exist, which may vary from state to state.

Supersedes all previous publications



WALRUS PUMP CO., LTD.

Web: www.walruspump.com